



**US Army Corps
of Engineers®**
Engineer Research and
Development Center



Modules for Modeling Firing Range Best Management Practices within TREECS™

Mark S. Dortch and Jeffrey A. Gerald

July 2015

The U.S. Army Engineer Research and Development Center (ERDC) solves the nation's toughest engineering and environmental challenges. ERDC develops innovative solutions in civil and military engineering, geospatial sciences, water resources, and environmental sciences for the Army, the Department of Defense, civilian agencies, and our nation's public good. Find out more at www.erdclibrary.usace.army.mil.

To search for other technical reports published by ERDC, visit the ERDC online library at <http://acwc.sdp.sirsi.net/client/default>.

Modules for Modeling Firing Range Best Management Practices within TREECS™

Mark S. Dortch

*Los Alamos Technical Associates
999 Central Avenue, Suite 300
Los Alamos, NM 87544*

Jeffrey A. Gerald

*Environmental Laboratory
U.S. Army Engineer Research and Development Center
3909 Halls Ferry Road
Vicksburg, MS 39180-6199*

Final report

Approved for public release; distribution is unlimited.

Abstract

The Training Range Environmental Evaluation and Characterization System (TREECS™) was developed for Army firing and training ranges. TREECS™ contains varying levels of capability to forecast the fate and risk of munitions constituents (MC), such as metals and high explosives (HE), located within firing and training ranges and transported to surface water and groundwater. The overall purpose of TREECS™ is to provide environmental specialists with tools to assess the potential for MC migration into surface water and groundwater systems and to assess military range management strategies to ensure protection of human health and the environment. TREECS™ can be used to assess best management practices (BMPs) for military ranges to avoid, reduce, and remediate MC concentrations in receiving waters. New modules for simulating the effectiveness of BMPs have been developed for future implementation into TREECS™. This report documents the final mathematical formulations, model implementation protocols, and input requirements of these modules.

DISCLAIMER: The contents of this report are not to be used for advertising, publication, or promotional purposes. Citation of trade names does not constitute an official endorsement or approval of the use of such commercial products. All product names and trademarks cited are the property of their respective owners. The findings of this report are not to be construed as an official Department of the Army position unless so designated by other authorized documents.

DESTROY THIS REPORT WHEN NO LONGER NEEDED. DO NOT RETURN IT TO THE ORIGINATOR.

Contents

Abstract	ii
Figures	v
Preface	vi
Unit Conversion Factors	vii
Acronyms, Abbreviations, and Symbols	viii
1 Introduction.....	1
Background	1
Objective	2
Report layout	2
2 Formulation and Implementation of BMP Modules	3
Background	3
Source removal.....	4
<i>Soil removal</i>	6
<i>Landscape burning</i>	7
<i>Phytoextraction</i>	7
<i>Phytotransformation</i>	9
<i>Selective MC removal</i>	10
<i>Implementation</i>	11
AOI export treatment.....	13
<i>Degradation reactor</i>	14
<i>Sedimentation Basin</i>	15
<i>Implementation</i>	17
3 Inputs and outputs.....	24
Source removal BMP inputs	24
<i>Soil removal and landscape burning</i>	24
<i>Phytotransformation</i>	25
<i>Phytoextraction</i>	26
<i>Selective MC removal</i>	26
AOI export treatment BMP inputs.....	27
<i>Degradation reactor</i>	27
<i>Sedimentation basin</i>	28
<i>Vadose zone reactor and tandem treatment</i>	28
Outputs	29
<i>Source removal</i>	29
<i>AOI export treatment</i>	29
4 Summary.....	31

References32

Report Documentation Page

Figures

Figures

Figure 1. New input file for Tier 2 soil model with source removal BMPs.	13
Figure 2. Example soil model UI processed input file for AOI export tandem treatment model.	20
Figure 3. Schematic of AOI export treatment models and related processing.	22
Figure 4. Preliminary input screen for soil removal and landscape burning BMPs.	25
Figure 5. Preliminary input screen for phytotransformation BMP.	26
Figure 6. Preliminary input screens for phytoextraction BMP.	26
Figure 7. Preliminary input screens for selective MC removal BMP.	27
Figure 8. Preliminary input screen for degradation reactor BMP.	28
Figure 9. Preliminary input screen for sedimentation basin BMP.	28
Figure 10. Example output for tandem AOI export treatment BMP.	30

Preface

This study was funded by the U.S. Army's Environmental Quality and Installations (EQI) Research Program. The work reported herein was conducted by Dr. Mark Dortch under contract to Los Alamos Technical Associates, which was under contract to the U.S. Army Engineer Research and Development Center (ERDC), and Jeffrey Gerald of the Water Quality and Contaminant Modeling Branch (WQCMB), Environmental Processes and Effects Division (EPED), Environmental Laboratory (EL) of ERDC.

The study was conducted under the general direction of Dr. Billy Johnson, WQCMB, principle investigator under the Green Range project that supported this work; Dr. Dorothy Tillman, Chief, WQCMB; Dr. Warren Lorentz, Chief, EPED; and Dr. Beth Fleming, Director of the EL. Dr. Elizabeth Ferguson was Technical Director of military materials in the environment. John Ballard was Program Manager for the EQI Research Program, and Jerry Miller was manager of the Green Range Project of EQI.

LTC John T. Tucker III was the Acting Commander and Dr. Jeffery P. Holland was the Director of ERDC.

Unit Conversion Factors

Multiply	By	To Obtain
acres	4046.86	square meters
metric tons	1000	kilograms

Acronyms, Abbreviations, and Symbols

Acronyms and Abbreviations

AOI	area of interest, such as HE impact area
BMP(s)	best management practice(s)
CASRN	chemical abstracts service registry number
DG	down-gradient
diss	dissolved MC mass
DU	depleted uranium
EL	Environmental Laboratory
EPED	Environmental Processes and Effects Division
ERDC	Engineer Research and Development Center
EQI	U.S. Army's Environmental Quality and Installations Research Program
fluxin	MC mass flux entering an AOI export treatment system
HE	high explosives
MC	munitions constituents, such as metals and HE
part	particulate MC mass
RDX	Research Department Explosive, a high explosive
SAFRs	small arms firing ranges
SW	surface water
TREECS™	Training Range Environmental Evaluation and Characterization System
trp	File extension for a TREECS™ project application file
TSS	total suspended solids concentration
UI	user interface for entering and viewing model inputs
UXO	unexploded ordnance
VZ	vadose zone
WFF	water flux file used in TREECS™
WQCMB	Water Quality and Contaminant Modeling Branch

Mathematical Symbols

A	surface area of AOI, m^2
A_b	surface area of a sedimentation basin, m^2
BCR	bioconcentration ratio, $mg\ MC\ in\ plant/kg\ plant / mg\ MC\ in\ soil/kg\ soil$ (dimensionless), where all mass is dry mass
B_R	AOI burn rate for source removal, acres/yr
C	dissolved MC concentration in the reactor pore water, mg/L
C_i	dissolved MC concentration in water entering the reactor, mg/L

C_L	dissolved MC concentrations in water exiting the reactor, mg/L
C_T	MC total (dissolved and particulate) concentration in water within and exiting a sedimentation basin, mg/L
C_{Ti}	total (dissolved and particulate) influent MC concentration for degradation reactor and sedimentation basin, mg/L
C_{tt}	total (particulate, dissolved, and vapor) non-solid phase MC concentration within the soil matrix on a total volume basis, g/m ³
D_x	dispersion coefficient in the reactor flow, m ² /day
E	AOI soil erosion rate, m/day or m/yr
F_c	combined surface water MC flux from AOI excluding soil interflow, g/day or g/yr
F_{dis}	solid phase MC dissolution flux, g/yr
F_{dp}	factor used to convert from total concentration on a total volume basis to dissolved concentration in the porous media on a total volume basis, dimensionless
F_d	fraction of MC total concentration in water that is in dissolved form, dimensionless
F_e	MC flux leaving AOI due to soil erosion, g/yr
F_{es}	MC flux leaving AOI due to erosion of solid phase MC particles, g/yr
F_i	MC flux leaving AOI due to soil interflow, g/yr
F_l	MC leaching flux from AOI, g/yr
F_p	fraction of MC total concentration in water that is in particulate form, i.e., adsorbed to TSS, dimensionless
F_{precip}	precipitation flux due to dissolved pore water MC concentration within AOI exceeding the MC water solubility limit, g/yr
F_r	runoff MC flux from AOI, g/yr
F_{sbd}	dissolved MC flux exiting a sedimentation basin, g/day or g/yr
F_{sbp}	particulate MC flux exiting a sedimentation basin, g/day or g/yr
F_{tp}	influent and effluent MC flux of a degradation reactor that is in particulate form and is untreated, g/day or g/yr
f_B'	fraction of AOI soil that is burned each year, 1/yr
f_H	fraction of the plant production rate that is harvested during phytoextraction; also fraction of AOI treated with phytoextraction, dimensionless

f_P	fraction of AOI area that is treated with phytotransformation, dimensionless
f_s'	fraction of AOI soil that is removed each year, 1/yr
f_T	fraction of plant uptake (bioaccumulation) of MC that is transformed, dimensionless
f_t	fraction of total flow and mass flux from AOI to surface water that is treated by a degradation reactor and/or sedimentation basin; fraction of total flow and mass flux from AOI to vadose zone that is treated by a degradation reactor, dimensionless
G	plant production rate, kg dry plant mass/m ² -yr
H_E	Henry's law constant, atm-m ³ /g-mole
H_r	reactor dimension (e.g., depth) perpendicular to flow axis, m
i	indicator for each year in a time series
j	indicator for each MC in a list of MC
K_d	sorption distribution coefficient for partitioning an MC between soil particles and water, L/kg
K_{dr}	sorption distribution coefficient for partitioning an MC between reactor media and water, L/kg
K_{dw}	sorption distribution coefficient for partitioning an MC between water and solids suspended in water, L/kg
K_H	dimensionless Henry's constant for partitioning between air and water
L_r	length of the reactor along the flow axis, m
$L(t)$	time-varying solid phase MC mass loading, g/yr
M_s	solid phase MC mass, g
Q	water flow rate through a degradation reactor or sedimentation basin, m ³ /day or m ³ /yr
Q_i	soil interflow flow rate, m ³ /day or m ³ /yr
Q_l	leaching flow through vadose zone, m ³ /day or m ³ /yr
Q_r	overland runoff flow rate, m ³ /day or m ³ /yr
Q_T	total water flow rate from AOI to surface water (excluding soil interflow, thus, equals runoff flow) or to vadose zone (equals leaching flow Q), m ³ /day or m ³ /yr
R	reactor retardation factor, dimensionless
RE	removal or trapping efficiency of a sedimentation basin to remove contaminants from the influent, percent
R_{ns}	non-solid phase MC source or inventory first-order removal rate, yr ⁻¹

R_s	MC solid phase source or inventory first-order removal rate, yr ⁻¹
R_u	the universal gas constant = 8.206 E-5 atm-m ³ /g-mol- °K
SR	MC mass selective removal rate, g/yr
S_r	soil removal rate, metric tons/yr
T_a	ambient absolute temperature, °K
$T_{1/2}$	half-life due to phytotransformation, yr
TSS	total suspended solids concentration within and exiting a sedimentation basin, mg/L
TSS_i	total suspended solids concentration of the influent to a sedimentation basin, mg/L
TSS_{ir}	total suspended solids concentration of the influent to a reactor, mg/L
t	time, yr or day
U	Darcy transit speed through the reactor, m/day
V_b	volume of water in a sedimentation basin, m ³
v_s	settling rate of suspended solids in a sedimentation basin, m/day
W_r	reactor dimension (e.g., width) perpendicular to flow axis, m
x	distance along the flow axis of a degradation reactor, m
Z_b	surficial soil layer thickness of AOI, m
λ_r	first-order degradation rate of MC within reactor, day ⁻¹
λ_d	reactor degradation rate for dissolved MC, day ⁻¹
λ_p	degradation rate for MC adsorbed to reactor material, day ⁻¹
v	pore water velocity in the reactor flow, m/day
ϕ	AOI soil porosity, fraction
ϕ_r	porosity of the reactor media, fraction
ρ_b	soil dry bulk density, g/cm ³ or kg/L, g/m ³ , and kg/m ³
ρ_{br}	dry bulk density of the reactor media, kg/L
ρ_w	density of water, g/cm ³
θ_w	soil volumetric moisture content or ratio of water volume to total volume, fraction; θ_w can't be greater than soil porosity

1 Introduction

Background

The Training Range Environmental Evaluation and Characterization System (TREECS™) was developed for Army firing and training ranges. TREECS™ contains varying levels of capability to forecast the fate and risk of munitions constituents (MC), such as metals and high explosives (HE), located within firing and training ranges and transported to surface water and groundwater. The overall purpose of TREECS™ is to provide environmental specialists with tools to assess the potential for MC migration into surface water and groundwater systems and to assess military range management strategies to ensure protection of human health and the environment.

Firing and training range Best Management Practices (BMPs) can be implemented to reduce MC migration and media concentrations. BMPs can include range use strategies as well as remediation alternatives. Military range BMPs for MC reduction generally fall under the following five broad categories (Dortch et al. 2013):

1. Source loading management: reduce loadings to the area of interest (AOI).
2. Source removal: remove MC mass from the AOI.
3. Source treatment: treat MC mass within the AOI to reduce export from the AOI.
4. AOI export treatment: treat AOI MC export (transport) fluxes as they exit the AOI.
5. Down-gradient receiving water treatment: treat MC within down-gradient receiving waters.

Examples of an AOI include the impact area of fired medium and large caliber munitions, firing points, impact berms for small arms firing ranges (SAFRs), demolition sites, grenade ranges, etc.

Source loading management can involve rotating range use over time for example, or simply varying the numbers and/or types of items fired each year. Source removal, the second BMP category, includes soil excavation or removal, controlled burning on the landscape, phytoextraction, and selective removal of MC mass. The third BMP category, source treatment,

involves treatment technologies within the AOI that more fully sequester MCs in AOI soil, such as soil amendments that reduce metal solubility and dissolution (Larson et al. 2007), or that enhance MC degradation, such as adding hydrated lime for alkaline hydrolysis of high explosives (Larson et al. 2008 and Gent et al. 2010). Although Phytotransformation is a source treatment BMP, it can also be classified as source removal. The fourth BMP category is referred to as AOI exit (or export) treatment because it addresses MC removal after it leaves the AOI and before reaching down-gradient receiving waters. Three types of export treatment devices are addressed: degradation reactors; sedimentation basins; and filter tubes. Down-gradient receiving water treatment refers to MC removal within off-site waters. This fifth category can include treatment within various types of surface waters, such as wetlands, ponds, lakes, and streams, as well as groundwater remediation.

Objective

A previous report by Dortch et al. (2013) presented formulations and software implementation and application guidance for modeling various range BMPs within all five of the above BMP categories. BMP modules were developed for future implementation into TREECS™ following publication of that report. Adaptations of the implementation recommendations were required. The primary objective of this report is to document the final mathematical formulations and software implementation protocols of TREECS™ BMP modules. Much of the coding for the final modules had been written and tested at the time of this publication, but their final implementation within TREECS™ had not been completed.

Report layout

Chapter 2 documents the final formulations and implementation protocols of the new modules in TREECS™ for evaluating BMPs. Chapter 3 describes input requirements and output for each BMP module. Chapter 4 provides a brief summary.

2 Formulation and Implementation of BMP Modules

Background

As noted in Chapter 1, the five general categories for range BMPs are:

1. Source loading management: reduce loadings to the AOI.
2. Source removal: remove MC mass from the AOI.
3. Source treatment: treat MC mass within the AOI to reduce export from the AOI.
4. AOI export treatment: treat AOI MC export fluxes as they exit the AOI.
5. Down-gradient receiving water treatment: treat MC export fluxes within down-gradient receiving waters.

Dortch et al. (2013) explained that TREECS™ could be used in its original form (prior to adding any BMP modules) to address BMP categories 1, 3, and 5. Although not reiterated here, Dortch et al. (2013) also discussed the appropriate application of TREECS™ to address BMPs within each of these three categories.

Phytoremediation includes phytoextraction, phytostabilization, and phytotransformation. Phytoextraction is the uptake of MCs by plants without significantly changing the MC chemical form and harvesting or removal of the plants, thus extracting the MC from the AOI. Plants can uptake metals, which do not transform. Thus, phytoextraction is a form of source removal. Phytostabilization is the use of plants to stabilize the soil to reduce erosion. TREECS™, in its original form, can address this type of BMP by using a different type of land cover and condition to estimate a revised soil erosion rate. Phytotransformation is the uptake of MCs by plants and transformation of the MC to a different, less harmful chemical. Phytotransformation technically falls into BMP category 3 or source treatment, but it can also be considered a source removal, as is the case here.

This chapter describes the new modules required by BMP categories two and four. Some of the BMP formulations are the same as presented by

Dortch et al. (2013), but they are repeated here for completeness since several formulations have changed.

Source removal

Source removal can involve five methods: removal of soil containing MC; burning of the landscape to destroy MC; phytoextraction, where plants uptake MC and are harvested or removed from the AOI; phytotransformation, where plants uptake MC and transform it to other forms; and selective removal of MC, including unexploded ordnance (UXO) removal. Soil removal usually involves excavating and processing soils from impact berms of SAFRs to extract metals. Burning of the landscape has been considered for removing combustible MCs, such as HE and propellants. Although phytotransformation is technically a source treatment, it is included in the source removal BMP category to simplify module implementation. Selective removal of MCs includes UXO dud removal and removal of metal and exposed HE chunks. All five of these removal methods can be addressed with modifications to the existing TREECS™ Tier 2 soil model as explained below.

Since new loss terms are involved, all of the BMP source removal modules required changes to the Tier 2 soil model that is in TREECS™. There are three new MC mass loss terms associated with source removal BMPs. These loss terms include: a first-order loss rate of solid phase MC mass; a first-order loss rate of non-solid phase MC mass following dissolution by water; and a zero-order loss rate of solid phase MC mass. There are two versions of the Tier 2 soil model, one for constant average, annual hydrology, and one for time-varying, daily hydrology. Both versions were modified to handle source removal BMPs.

The solid phase MC mass balance equation for AOI soil with zero-order and first-order losses due to source removal BMPs is

$$\frac{dM_s}{dt} = L(t) - F_{dis} - F_{es} + F_{precip} - R_s M_s - SR \quad (1)$$

where,

M_s = solid phase MC mass, g

t = time, yrs

$L(t)$ = time-varying solid phase MC mass loading, g/yr

- F_{dis} = MC dissolution flux, g/yr
 F_{es} = erosion flux of solid phase MC particles, g/yr
 F_{precip} = precipitation flux of MC due to dissolved pore water concentration exceeding the water solubility limit, g/yr
 R_s = first-order MC mass loss rate due to source removal BMPs, 1/yr
 SR = zero-order MC loss rate due to source removal BMPs, g/yr

The last two terms on the right-hand side of Equation 1 are two of the three new loss terms of the AOI soil model. Otherwise, the remainder of Equation 1 is the same as the original version of the Tier 2 soil model as described by Dortch et al. (2011). It is noted that M_s is the mass of MC prior to dissolution into water where it can partition among water, soil, and air within the soil matrix.

The mass balance for non-solid phase MC mass with a first-order mass loss rate due to source removal BMPs is stated as

$$\frac{dC_{tt}}{dt} = \frac{F_{dis}}{AZ_b} - \left[\frac{d_e}{Z_b} (1 - e^{-\kappa}) N + \frac{E}{Z_b} + \frac{q_w}{\theta_w Z_b} F_{dp} + (\lambda_l F_{dp} + \lambda_a F_{pp}) + \frac{K_v}{Z_b} F_{ap} + R_{ns} \right] C_{tt} - \frac{F_{precip}}{AZ_b} \quad (2)$$

where C_{tt} is the total concentration of non-solid phase MC on a total volume basis (grams/cubic meter), and R_{ns} is the first-order non-solid phase MC removal rate (per year) due to source removal BMPs. Dortch et al. (2011) defined all other terms in the above equations; however, they are not repeated here for brevity. The only change to Equation 2 from the original model (Dortch et al. 2011) is the addition of the last term within the bracket on the right-hand side, R_{ns} .

Three new parameters have been included within the Tier 2 soil model, R_s , R_{ns} , and SR . The model reads in these three parameters from a new input file that is generated from user inputs entered on the BMP input screens of the Tier 2 soil model user interface (UI). Each of these three parameters can vary over time and is the sum of all source removal BMPs. The calculation of the contribution of each source removal BMP to these three terms is explained below.

Soil removal

Depending on the follow-up treatment, soil removal can result in first-order losses for both solid phase and non-solid phase MC or only first-order loss of solid phase MC. For example, if soil is permanently removed from the AOI, then both types of losses occur. However, if soil is processed on-site to remove solid MC particles, such as lead, and returned to the AOI, then only solid phase MC removal is involved.

The source removal rate R_s (per year) for solid phase MC due to soil removal is computed as follows:

$$R_s(\text{soil removal}) = \frac{S_r}{(\rho_b + \theta_w \rho_w) AZ_b} = f'_s \quad (3)$$

where S_r is the soil removal rate (metric tons/year), ρ_b is the soil dry bulk density (grams/cubic centimeter), θ_w is the soil volumetric moisture content (a fraction that is less than the porosity), ρ_w is the density of water (approximately 1.0 grams/cubic centimeter), and the product AZ_b is the AOI total soil volume (cubic meters) including water and air spaces. A factor of 1.0E6, which is the conversion from metric tons to grams, is cancelled by the factor 1.0E6, which is required to convert soil bulk density and water density in grams/cubic centimeters to units of grams/cubic meter. A is the AOI surface area (square meters), and Z_b is the AOI active (contaminated) soil layer thickness (meters). The right-hand side of Equation 3 is also equal to the fraction of AOI soil that is removed each year, f'_s (per year).

The constraint placed on the computed value of R_s (*soil removal*) is that it cannot be greater than 1.0. Values greater than 1.0 are not allowed since this would result in more soil being removed in a year than is available within the AOI active soil layer. The only new input required for Equation 3 is S_r , which can vary over time. The UI provides an input table for pairs of time (year) and S_r for that year. As with other time-varying inputs, at least two time-pairs are required, and values are held constant until the next update time. The soil removal rate is not MC-specific; thus, only a single entry is required for each update year and applies to all MCs.

If soil is permanently removed from the AOI, then the non-solid phase MC removal rate R_{ns} is set equal to R_s for this BMP with the same constraint of

not allowing values greater than 1.0. The user declares whether R_{ns} is zero or equal to R_s , and this declaration applies to all MCs. The parameter SR is zero for this BMP.

Landscape burning

It is possible to remove reactive MCs, such as explosives and propellants, through combustion by burning the landscape. Burning is MC-specific since some MCs, such as metals, do not burn. The solid phase MC removal rate due to burning is computed from

$$R_s(\text{burning}) = 4,047 \frac{B_R}{A} = f'_B \quad (4)$$

where B_R is the burn rate (acres/year), and the factor 4,047 is the conversion from acres to square meters. The value of R_{ns} is set to equal to R_s for burning. Computed values of R_s (as well as R_{ns}) for burning are not allowed to be greater than 1.0 since R_s is equivalent to the fraction of the AOI landscape that is burned each year, f'_B (per year). The user must select which MCs are burned since some MCs, such as metals, do not burn. An input table is provided for entering pairs of time and burn rate. The value of SR is zero for this BMP.

Phytoextraction

It is assumed that plants can take up only dissolved MCs; therefore, the value of R_s is set to zero for this BMP. The value of SR is also zero for this BMP. The value of R_{ns} is computed as follows to account for phytoextraction:

$$R_{ns}(\text{phytoextraction}) = \frac{F_{dp} f_H G BCR}{Z_b \rho_b} \quad (5)$$

where

F_{dp} = dimensionless factor to account for the soil pore-water-dissolved portion of the total non-solid phase MC concentration in soil

f_H = fraction of the plant production rate that is harvested each year (also fraction of AOI used for phytoextraction)

G = plant production rate, kg dry plant mass/m²-yr

BCR = bioconcentration ratio, mg MC in plant/kg plant / mg MC in soil/kg soil (dimensionless), where all mass is dry mass

Other terms are the same as defined previously. Assuming that all plants are harvested each year within an area being treated with phytoextraction, the fraction of the plant production rate that is harvested, f_H , is the same as the fraction of the AOI that is treated with phytoextraction; thus, this fraction is not allowed to be greater than 1.0.

The formulation for computing F_{dp} is

$$F_{dp} = \frac{\theta_w}{\theta_w + (\phi - \theta_w)K_H + \rho_b K_d} \quad (6)$$

where

θ_w = soil volumetric moisture content or ratio of water volume to total volume, fraction; θ_w can't be greater than soil porosity

ϕ = sediment porosity or ratio of void volume to total volume, fraction

K_d = sorption distribution coefficient for partitioning a constituent between soil particles and water, L/kg

K_H = dimensionless Henry's constant for partitioning between air and water

All variables in Equation 6 are known by the UI for computing F_{dp} . K_H is computed by the soil model UI from Henry's law constant H_e (atmosphere-cubic meter/gram molecular weight), which is supplied by either the MC data base used in TREECS™ or the user:

$$K_H = \frac{H_e}{R_u T_a} \quad (7)$$

where R_u is the universal gas constant = 8.206 E-5 atm-m³/g-mol- °K, and T_a is ambient absolute temperature (degrees kelvin), or soil-water matrix temperature in this case, which is the matrix temperature in degrees Celsius plus 273. All of the right-hand side parameters in Equations 5 – 7 are presently soil model UI inputs or are computed from inputs with the exception of f_H , G , and BCR , which are all MC-dependent. The first two parameters indirectly depend on MC due to different plants being used for

different MC, and BCR is directly MC and plant dependent. It is noted that F_{dp} can vary over time when time-varying hydrology is used due to time-varying soil water content. Soil water content is available within a time-varying hydrology input file used by the soil model.

The fraction of the AOI used for phytoextraction can vary by MC and over time. Thus, an input table similar to before is available to enter time (years) and f_H input pairs for each MC. A check is made to ensure that none of the f_H inputs for any MC is greater than 1.0 for all time pairs. The assumption is made that G and BCR are constant over time for each MC. The values for G and BCR are not assumed to be the same as those entered for phytotransformation.

Burning for phytoextraction is assumed to be independent of burning the landscape for source removal. The method of harvesting or plant extraction is not a model feature. Similar to burning, phytoextraction may not apply to all MCs; thus, the user is required to select which MCs are applicable to phytoextraction.

Phytotransformation

Phytotransformation is a BMP that is MC-dependent and can vary over time. Phytotransformation is assumed to occur only for pore-water, dissolved MC; thus, the solid phase MC removal rate R_s is zero for this BMP. The value of SR is also zero for this BMP. The non-solid MC removal rate R_{ns} for this BMP is computed from

$$R_{ns}(\text{phytotransformation}) = f_p \frac{F_{dp} G BCR f_T}{Z_b \rho_b} \quad (8)$$

where

f_p = fraction of AOI area that is treated with phytotransformation, dimensionless

f_T = fraction of plant uptake (bioaccumulation) of MC that is transformed

All other terms have been defined preciously, but it is emphasized that values used for G and BCR in phytotransformation can be different from those used in phytoextraction. The soil UI already had inputs for Z_b and ρ_b ,

and information is available for computing F_{dp} , as explained above, for phytoextraction; thus, the input screen for phytotransformation includes inputs for f_p , G , BCR , and f_T . Each of these four inputs can be MC-specific. Plant production rate can be independent of MC, but different plants could be used for different MC; thus, G could depend indirectly on MC.

Phytotransformation can vary with time throughout the simulation. The inputs G , BCR , and f_T are assumed to be constant over time for each MC. However, the input f_p is allowed to be time varying for each MC; thus, time pairs for f_p must be entered for each MC. A check is included in the UI to ensure that none of the f_p inputs for any MC is greater than 1.0 for all time pairs since treating more area than the AOI is not allowed. Additionally, the fraction f_T cannot exceed 1.0.

The phytotransformation rate R_{ns} is similar to a degradation rate. The half life $T_{1/2}$ (years) for this degradation rate can be obtained from

$$T_{1/2} = \frac{0.693}{R_{ns}} \quad (9)$$

The time versus f_p table displays the computed removal rate, R_{ns} , and half-life for phytotransformation.

Selective MC removal

Selective MC removal includes UXO duds as well as chunks of exposed metals and HE. Duds are munitions that do not encounter any explosion. Sometimes range clearance personnel remove duds from firing ranges. Although UXO removal is performed primarily to remove intact duds, there can be exposed chunks of HE from low order detonations that can be removed. The extraction of metal particles from impact berms of SAFRs via soil processing can be addressed as soil removal, but it can also be addressed via the *Selective MC Removal of Chunks* BMP. This BMP module was designed to allow selective removal of MC mass, and is handled with the zero order MC mass removal rate SR (grams/year). Although metal particles such as lead in SAFRs can be addressed with this BMP, it was really intended for exposed chunks of HE and large metal chunks typically associated with spotting projectiles that do not explode, such as those containing depleted uranium (DU) that were used in the Davy Crockett training round.

Presently, duds only contribute to MC residue loading if percentages for sympathetic duds and their yield are set greater than zero in the *Operational Inputs* screen on the *Site Conditions* tab. TREECS™ presently does not handle corrosion and perforation of duds that can expose HE. Sympathetic duds are low order detonations due to another round exploding close enough to the dud to cause it to explode or causing the dud casing to open, thus exposing HE. Although the default values are zero, the user can enter the percentages for sympathetic duds and their yield. If the percentage of sympathetic duds remains zero, this can mean that either all of the duds are removed or none of them exploded sympathetically; therefore, HE source removal associated with UXO dud clearance does not require any modifications to TREECS™. The user can simply leave the percentage of sympathetic duds set to zero, which has the same effect as removing all duds.

Selective removal of exposed HE and metal chunks can be addressed by the user specifying which MCs are selectively removed and setting values for *SR*, i.e., the amount of solid phase MC mass that is removed from the AOI each year for each MC. Thus, *SR* is MC-specific, and a table is provided for entering yearly time-*SR*-pairs.

Implementation

Each of the five source removal BMPs are implemented as options in the Tier 2 soil model UI under the *Source Removal BMPs* tab. It is possible to include any and all of these five types (i.e., soil removal, burning, phytoextraction, phytotransformation, and selective MC removal of chunks). However, the first four source removal types are assumed to be mutually exclusive. Mutual exclusion means that if a portion of the AOI is treated with one method, such as soil removal, then that area cannot be treated with any other method, such as burning, phytoextraction, or phytotransformation. There is an overall criteria check in the soil model UI to ensure that the user is not using more area for treatment than exists within the AOI. The UI for soil removal or burning adds the two removal rates f'_s and f'_b to ensure that their sum does not exceed 1.0 for all time pairs. Furthermore, the sum of AOI treatment fractions (and/or fraction rates) for the first four removal methods should not exceed 1.0 for all years. The overall criteria can be expressed mathematically as follows,

$$\max_{j=1}^M f_{P_{i,j}} + \max_{j=1}^M f_{H_{i,j}} + f'_{s_i} + f'_{B_i} \leq 1.0 \quad (10)$$

where j represents each MC, M is the total number of MC, and i represents a specific year with input. Equation 10 must be satisfied for each input year, and it conceptually states that if a portion of the AOI is treated with one method, it cannot be treated with any other method in a given year. The purpose of Equation 10 is to avoid over counting for different treatment options. Equation 10 is not invoked until after all inputs have been entered and the user saves the soil model UI inputs. If Equation 10 is violated, the UI displays a screen stating “Source removal BMPs should not be applied for an area larger than the AOI in a given year. Inputs should be adjusted to reduce BMP treatments to satisfy this constraint. Prior inputs have not been saved.” At this point, the user must adjust inputs to satisfy the constraints in order to save inputs.

It is noted that the implementation of BMP treatment options results in conservative MC removal rates since the AOI is treated as a single homogeneous area. For example, if half of the AOI soil is removed each year, then all of the MC source mass should be removed after two years assuming that there is no additional source of MC and only the contaminated half is removed the second year. However, with a homogenous AOI without spatial discretization, 61 % of the MC mass will remain after the first year, and 37 % will remain after two years. The lumped spatial aspect of this model results in a slower, exponential loss in MC mass.

All five source removal BMP options involve inputs as time pairs. All of the input pairs are MC dependent except for soil removal. The Tier 2 soil model UI computes values for R_s and R_{ns} for each BMP option, for each MC, and for each update year. The UI then sums each of these two parameters over all BMPs for each MC and each update year and writes the sums to a file that the Tier 2 soil model subsequently uses. Additionally, SR values are written to this file for each MC and each update year. The new file consists of two header lines for a title and other case information followed by a line with the MC name, its chemical abstract surface registry number (CASRN), and the number of lines in the time series. Each line of the time series has the values for the year, R_s , R_{ns} , and SR . Figure 1 shows an example of the new file.

Figure 1. New input file for Tier 2 soil model with source removal BMPs.

```
Example test case for BMPs
Data includes year, Rs(1/yr), Rns(1/yr), and SR(g/yr) for each constituent
Lead,7439921,2
0.0,0.1,0.1,2500.
100.0,0.1,0.1,2500.
RDX,121824,2
0.0,0.2,0.1,1400.
100.0,0.2,0.1,1400.
```

AOI export treatment

AOI export treatment involves the remediation of MC after it exits (i.e., exported from) the AOI in transit to down-gradient receiving waters. AOI export methods include surface water runoff from the AOI, including soil erosion, and leaching from AOI soil to the vadose zone. Mathematical models were developed as described by Dortch et al. (2013) for assessing two AOI export treatment options, a degradation reactor and a sedimentation basin. The degradation reactor can be used to treat either surface water export or export to the vadose zone. Additionally, the two treatment methods can be used in tandem (sedimentation followed by reactor) for surface water. The formulations for these two BMP options are presented below. The formulation for the reactor has not changed from the one presented by Dortch et al. (2013), but it is repeated here for completeness. The formulation for the sedimentation basin was revised from the original formulation by Dortch et al. (2013).

There is a third AOI export treatment option that can be modeled, which involves using filter tubes to trap or remove particulate and dissolved MC fluxes as they exit the AOI. Sand filter tubes are an effective means of trapping particulate metals (i.e., metals adsorbed to suspended solids). Sand mixed with other materials can remove particulate and dissolved MC. In most cases, filter tubes remove practically all exiting particulate MC and dissolved MC (with mixed filter material). Thus, assuming total MC removal with filter tubes is reasonable. With this assumption, no new TREECS™ modules are required to include the filter tube export treatment BMP. This BMP can be modeled by using the User Defined WFF module within the Advanced Tier 2 option of TREECS™ as described by Dortch (2014). This module is used in place of the Tier 2 soil model and allows the user to specify MC dissolved and particulate fluxes leaving the AOI. The Tier 2 soil model outputs dissolved and particulate fluxes leaving the AOI without filter tubes. Users can retrieve those outputs from a

previous run without BMPs and modify them as inputs for the User Defined WFF module as used for the filter tube BMP.

Degradation reactor

This model accounts for dissolved MC removal along the flow axis of the reactor. The reactor can be oriented horizontally or vertically to treat AOI runoff or infiltration, respectively. The reactor is assumed to be a water-saturated, porous medium with uniform dimensions perpendicular to the flow axis (i.e., width, W_r (meters), and depth, H_r (meters), for horizontal flow) and uniform media properties, such as reactor porosity, ϕ_r . MC concentration is assumed to be uniform except along the flow axis.

From Zheng and Wang (1999), the time-varying, one-dimensional reactive transport equation including sorption onto the solid media and degradation is

$$R \frac{\partial C}{\partial t} + v \frac{\partial C}{\partial x} = D_x \frac{\partial^2 C}{\partial x^2} - \lambda_d C - \lambda_p \frac{\rho_{br} K_{dr}}{\phi_r} C \quad (11)$$

where

C = dissolved MC concentration in the reactor pore water (mg/L)

t = time (days)

x = distance along the flow axis of the reactor (m)

ϕ_r = porosity of the reactor media, void or water volume / total volume

D_x = dispersion coefficient in the reactor flow (m²/day)

R = reactor retardation factor due to sorption (dimensionless)

v = pore-water velocity of the reactor flow, m/day; $v = U/\phi_r$, where U is the Darcy transit speed (m/day)

ρ_{br} = dry bulk density of the reactor media (kg/L)

K_{dr} = distribution coefficient for sorption partitioning in the reactor (L/kg)

λ_d = degradation rate for dissolved MC (day⁻¹)

λ_p = degradation rate for MC adsorbed to reactor material (day⁻¹)

For a given water inflow rate Q (cubic meters/day), the Darcy transit speed U (meters/day) through the reactor can be computed from $U = Q/(W_r H_r)$. Equation 11 assumes equilibrium partitioning and first-order reaction

kinetics. With linear partitioning, the reactor retardation factor is expressed as,

$$R = 1 + \frac{\rho_{br} K_{dr}}{\phi_r} \quad (12)$$

Neglecting dispersion and assuming that the degradation rates for dissolved and adsorbed MC are the same within the reactor ($\lambda_d = \lambda_p = \lambda_r$), Equation 11 can be written as

$$\frac{\partial C}{\partial t} + \frac{v}{R} \frac{\partial C}{\partial x} = -\lambda_r C \quad (13)$$

Assuming conditions are at steady-state, Equation 13 reduces to the following analytical solution for $x = L_r$, which is the total length of the reactor along the flow axis,

$$C_L = C_i \exp\left(-\frac{\lambda_r R L_r}{v}\right) \quad (14)$$

where C_i and C_L are the dissolved MC concentrations in water entering and exiting the reactor, respectively. This rather simple analytical solution can be applied over time with time-varying updates for flow rate and entering MC concentration (loading), but the output concentration is assumed to be at steady-state with respect to each input update, which means that steady-state is reached rather quickly relative to the flow/loading updates. This is expected to be the case for most of the time, especially if annual loadings are used. This model does not address the fate of particulate MC entering the reactor. Particulates could potentially settle in the reactor and degrade, but this feature is not supported. If substantial quantities of particulate MC are expected, then consideration should be given for either a sedimentation basin or tandem treatment with sedimentation followed by a reactor.

Sedimentation Basin

The purpose of this model is to predict the trapping and resulting exit concentrations of MCs that are passed to a sedimentation basin via overland flow. MCs with relatively high-suspended sediment – water partitioning distribution coefficients (K_{dw}), such as metals, would be most

appropriate for this type of treatment. The formulation of this model is described below.

The simplifying model assumption that is made is the sedimentation basin is fully mixed, i.e., a batch reactor. The only removal process is settling of particulate MC (i.e., adsorbed to total suspended solids, TSS). The mass balance of MC within the sedimentation basin is stated as follows,

$$V_b \frac{dC_T}{dt} = QC_{Ti} - QC_T - v_s A_b F_p C_T \quad (15)$$

where

- C_T = MC total (dissolved and particulate) concentration in water within and exiting the basin (mg/L)
- C_{Ti} = MC total concentration in water entering basin (mg/L)
- t = time (days)
- F_p = fraction of MC total concentration in water that is adsorbed to TSS
- Q = water flow rate into and exiting the basin (m³/day)
- A_b = water surface area of the basin, or volume/depth (m²)
- V_b = water volume of the basin (m³)
- v_s = settling rate of suspended solids (m/day)

The fraction of MC total concentration that is particulate F_p is computed from

$$F_p = \frac{10^{-6} TSS K_{dw}}{1 + 10^{-6} TSS K_{dw}} \quad (16)$$

where TSS is the total suspended solids concentration in milligrams/liter, and K_{dw} is the water-TSS distribution coefficient (liters/kilogram) for sorption partitioning of dissolved MC to TSS. The factors 10^{-6} in Equation 16 are the conversion from mg to kg that is required to convert TSS in mg/L to kg/L.

A TSS mass balance must be conducted for the sedimentation basin using an analogous form of Equation 15 where C_T and C_{Ti} in Equation 15 are replaced with TSS and TSS_i , respectively, and F_p is set to 1.0. TSS_i is the basin influent TSS concentration (mg/L and g/m³) and is computed from

$$TSS_i = \frac{1.0E^6 \rho_b A E}{Q_T} \quad (17)$$

where

- E = AOI soil erosion rate (m/day)
- Q_T = total water flow rate from AOI to all down-gradient surface waters (m³/day)
- A = AOI surface area (m²)
- ρ_b = AOI soil dry bulk density, kg/L

The factor 1.0E6 in Equation 17 is the conversion from kg/L to g/m³ or mg/L.

The equations above are solved using the second order accurate Heun method with an adaptive time step of 0.2 days or less to maintain numerical stability. The equation integration is performed for daily updates of both C_T and TSS .

Implementation

Three AOI export treatment models have been developed as stand-alone FORTRAN codes: degradation reactor for surface water and vadose zone, sedimentation basin for surface water, and sedimentation basin and reactor in tandem for surface water. The Tier 2 soil model UI determines which models to execute based on user inputs. A processor within the UI prepares input files for each treatment model and writes output files for use by down-gradient models. This section describes the processing performed for implementing the aforementioned AOI export treatment BMP models.

There are two versions of the Tier 2 soil model, one that uses average annual hydrology and one that uses daily hydrology. For these reasons, mass and water volume fluxes can involve daily or annual units, i.e., grams/year or grams/day and cubic meters/year or cubic meters/day. Both the reactor and sedimentation basin models process daily water flows and mass fluxes regardless of whether annual average or daily hydrology is used. Thus, a soil model UI processor converts hydrology data into daily units for use in the AOI export treatment BMP models.

It is possible that some of the water flows and mass fluxes exiting the AOI will not receive treatment. Some flows and fluxes may bypass the treatment reactor and/or sedimentation basin. Thus, the user is required to enter the fraction of total flow and flux from AOI to surface water or vadose zone that is being treated, f_t . The soil model UI processor multiplies the AOI total export water flow rate and mass flux by this fraction to obtain the treated flows and fluxes that are input to the treatment system(s).

The Tier 2 soil model generates five output fluxes to comprise AOI MC mass export (mass/time) to down-gradient models: runoff flux (F_r), which is all dissolved; soil erosion flux (F_e), which includes dissolved and particulate (soil adsorbed) MC; soil interflow flux (F_i), which is dissolved; leaching flux (F_l), which is dissolved; and the flux due to erosion of solid phase MC (F_{es}), which is particulate since it has not yet dissolved. Soil erosion flux contains soil-adsorbed MCs and MCs dissolved in pore water. Without AOI export BMPs, the soil model UI processor accesses the five fluxes to create two types of output within the water flux file (WFF) used by down-gradient models, one for surface water and one for the vadose zone/groundwater. Both WFF output types contain MC mass fluxes (grams/year) and water flows (cubic meters/year). Time units of years are used in the WFF for both, average annual and time-varying, daily hydrology. The WFF surface water data also contains two data types for MC mass fluxes, dissolved and particulate, whereas all of the WFF vadose MC mass fluxes are dissolved. The WFF water flow rate to vadose zone, Q_l , consists of net infiltration after accounting for losses to ET and soil interflow. The WFF total water flow rate to surface water is the combination of runoff flow rate, Q_r , and soil interflow flow rate, Q_i , which resurfaces to surface water flow.

When AOI export BMPs are not used, the soil model UI processor combines F_r and F_i to form the combined dissolved flux within WFF surface water. When AOI export BMPs are used, the soil model UI processor excludes soil interflow fluxes from those being treated since it is assumed that all BMPs will be up-gradient of return flow from soil interflow; thus, soil interflow is not treated by AOI export BMPs. Likewise, the total (treated and untreated) surface water flow rate, Q_T , excludes interflow; thus, $Q_T = Q_r$.

The particulate flux of the WFF for surface water contains all of the erosion flux, whereas a portion of F_e is actually dissolved. This misrepresentation

presents no adverse consequences since the total MC flux (particulate and dissolved) is used to compute reactor influent partitioning and dissolved concentrations, as shown later below. Partitioning of influent is necessary since the distribution coefficient for surface water TSS can be quite different from that used for soil-pore-water.

When an AOI export BMP includes a sedimentation basin and/or a reactor for surface water, a soil model UI processor adds the fluxes F_r , F_e , and F_{es} to form F_c , which in this case is the combined MC overland total flux for surface water. The eroded solid phase MC overland flux F_{es} is included as if it is a non-solid flux although water has not dissolved it at this point. Assuming that water has dissolved it greatly reduces the complexity of implantation while contributing little inaccuracy. F_c is simply the leaching flux F_l for a vadose zone reactor; of course, F_c is multiplied by f_t to obtain the treated flux that is input to the BMP models.

The total (dissolved and particulate) influent concentration, C_{Ti} (grams/cubic meter) required for the sedimentation basin model is computed by the soil model UI processor from the ratio of AOI export flux and flow,

$$C_{Ti} = \frac{F_c}{Q_T} \quad (18)$$

where, as stated previously, Q_T is the total water flow rate from AOI to surface water due to overland runoff. For reactors in the vadose zone, Q_T is simply the leaching flow rate Q_l as stated previously. The reactor flow rate is $Q = f_t Q_T$. The untreated flow rate is $(1 - f_t) Q_T$, and the untreated flux is $(1 - f_t) F_c$. The soil UI processor tracks untreated flows and fluxes since they must be added to the treated flows and fluxes in the WFF for models down-gradient of the BMP models.

The dissolved influent concentration, C_i for a surface water reactor is determined from

$$C_i = F_d C_{Ti} \quad (19)$$

The fraction dissolved F_d is computed from

$$F_d = \frac{1}{1 + 10^{-6} TSS_{ir} K_{dw}} \quad (20)$$

where TSS_{ir} is the TSS concentration (milligrams/liter) entering the reactor. Without tandem treatment (i.e., no sedimentation upstream of the reactor), TSS_{ir} equals TSS_i as determined from Equation 17. For tandem treatment, TSS_{ir} equals TSS , which is the computed TSS concentration exiting the sedimentation basin. The latter distinction is handled within the tandem model.

The soil model UI processor assembles and calculates the AOI water flow rate, Q_T , and mass flux F_c for each day and writes the values to input files for the AOI export treatment models. Additionally, the processor calculates daily values of TSS_i and writes these to the same input files. The content of these input files varies depending on whether a reactor, sedimentation basin, or tandem treatment is used, but there is much similarity. Figure 2 shows an example of the tandem treatment input file produced by the processor.

Figure 2. Example soil model UI processed input file for AOI export tandem treatment model.

```

"test case for generic sedimentation basin and reactor in tandem for range BMPs"
"Basin surf area, m^2"      1000.
"Basin mean depth, m"      5.
"TSS settling rate, m/day"  2.0
"Reactor Length, m"       10.0
"Reactor Width, m"        3.0
"Reactor Height, m"       1.0
"Reactor Porosity"        0.50
"Reactor bulk density, kg/L" 1.4
"fraction export treated"  1.
"Number of MC"            2
"MC name"                 TNT
"MC CASID"                 118967
"TSS-water Kd"            1.0
"Reactor Kd, L/kg"        20.0
"Reactor reaction rate, 1/day" 10.0
"Number of time series"   22280
Runoff
  year  month  day  AOI flow m3/day  AOI Flux g/day  TSS mg/L
  1950   1     1     0           0           16800
  1950   1     2     0           0           16800
  1950   1     3    3224.78     430         16800
  1950   1     4     0           0           16800
  1950   1     5     0           0           16800
  1950   1     6     0           0           16800
  1950   1     7    3925.82     430         16800
  1950   1     8     0           0           16800
  1950   1     9     0           0           16800
  1950   1    10     0           0           16800
  1950   1    11     0           0           16800

```

The soil model UI processor assembles and writes information to the WFF for use by down-gradient models. Down-gradient receiving water models are usually required. For example, there may be a lake or stream down-gradient of the AOI export treatment system where MC concentrations must be predicted given that not all MC mass is removed by the treatment system. The processor assembles and combines down-gradient water flow

rate and mass fluxes for each MC for each day. Furthermore, the processor distinguishes the mass fluxes as dissolved and particulate as required by the WFF specifications. The AOI export treatment models accommodate this need as follows.

Since the reactor only removes dissolved MCs, the portion of reactor influent (and effluent) that is in particulate form (F_{tp}) must be tracked so that it can be passed to down-gradient models. The reactor particulate flux is computed within the reactor model from

$$F_{tp} = (1 - F_d) Q C_{Ti} \quad (21)$$

when a sedimentation basin is not upstream in tandem. When in tandem with a sedimentation basin, C_{Ti} in Equation 21 is replaced with C_T , which is the outflow total concentration for a sedimentation basin and is available within the tandem model.

Sedimentation basin total mass flux out is the product, QC_T . This total flux out is partitioned by the sedimentation basin model into particulate and dissolved fluxes (F_{sbp} and F_{sbd} , respectively) to maintain the two data types that are required within the WFF for surface water. This partitioning is computed as follows,

$$F_{sbp} = F_p C_T Q \quad (22)$$

$$F_{sbd} = (1 - F_p) C_T Q \quad (23)$$

where F_p is computed from Equation 16.

The soil model UI processor uses the dissolved and particulate effluent fluxes from the AOI export treatment models to develop the WFF used by down-gradient receiving water models. The treated output fluxes are added to the untreated AOI export fluxes as well as any soil interflow fluxes, and the combined results are written to the WFF. The two data types for surface water (dissolved and particulate) are maintained in the WFF by the processor. Figure 3 shows a schematic of the AOI export treatment models and related processing.

Figure 3. Schematic of AOI export treatment models and related processing.

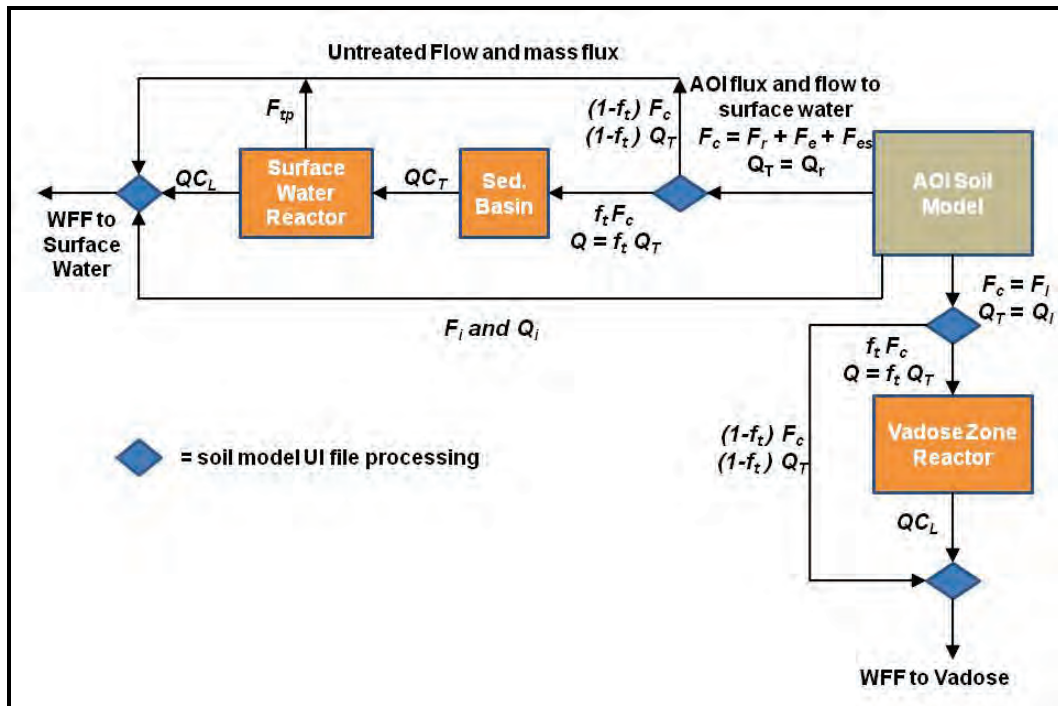

As stated previously, three AOI export treatment models have been developed as FORTRAN codes: degradation reactor for surface water and vadose zone, sedimentation basin for surface water, and sedimentation basin and reactor in tandem for surface water. Each of the three models can handle multiple MCs. These three treatment models can be applied in seven possible combinations:

1. Degradation reactor for surface water
2. Degradation reactor for vadose zone
3. Degradation reactor for surface water and vadose zone
4. Sedimentation basin for surface water
5. Tandem sedimentation basin and degradation reactor for surface water
6. Tandem sedimentation basin and degradation reactor for surface water and vadose zone reactor
7. Sedimentation basin for surface water and degradation reactor for vadose zone

However, the above combinations can be handled with three possible input options:

1. Degradation reactor for surface water
2. Degradation reactor for vadose zone
3. Sedimentation basin for surface water

If all three options are selected, condition six is invoked. If the first and third options are selected, condition five is invoked. If the second and third options are selected, condition seven is invoked, and so on.

3 Inputs and outputs

Input and output for the TREECS™ BMP modules are presented in this chapter. This information is organized in the same fashion as done in Chapter 2, source removal and AOI export treatment BMPs.

Source removal BMP inputs

The input information associated with each of the five source removal BMPs is presented in this section.

Soil removal and landscape burning

The Tier 2 soil model UI has a new tab labeled *Source Removal BMPs*. The inputs for all five source removal BMPs are entered via this tab. There are four sub-tabs on the *Source Removal BMPs* screen. These are labeled *Soil Removal/Burning*, *Phytotransformation*, *Phytoextraction*, and *Selective MC Removal of Chunks*. Figure 4 shows a preliminary version of the input screen with selection tabs. This version has phytotransformation as a separate tab rather than as a sub-tab under *Source Removal BMPs*. For the final software version, the phytotransformation BMP will be moved to a sub-tab.

Soil removal and burning of the landscape are combined on the same screen since the input requirements are conducive to combining them. For the final software version, the user will be required to check whether to set $R_{ns} = R_s$ or set R_{ns} to zero for soil removal. This feature was not included in the preliminary input screen shown in Figure 4. Setting $R_{ns} = R_s$ means the soil is permanently removed. Setting R_{ns} to zero means that solid MC particles are removed, and the soil is put back in place; thus, non-solid phase MCs are not removed.

Each MC included in the application is displayed along with its CASRN. As shown in Figure 4, the user selects the MC to which burning applies. In the lower panel of the screen, the user enters the soil removal rates in metric tons per year and the burning rate in acres per year for each year that there are changes in these two inputs. At least two time points in years must be entered, and inputs are stepped for each input year, i.e., they are constant until the next update year. The UI displays the computed values

for R_s and R_{ns} for soil removal and burning and checks to make sure the calculated values and their combination for soil removal and burning do not exceed 1.0 for any input year.

Figure 4. Preliminary input screen for soil removal and landscape burning BMPs.

Time (yr)	Soil Removal Rate (metric)	Burning Rate (acres/yr)	Calculated R_s (soil removal) (/yr)	Calculated R_{ns} (soil removal) (/yr)	Calculated R_s (burning) (/yr)	Calculated R_{ns} (burning) (/yr)
0	10000	50	0.050908785936...	0.050908785936...	0.688265306122...	0.688265306122...
100	10000	50	0.050908785936...	0.050908785936...	0.688265306122...	0.688265306122...

Phytotransformation

The input screen for phytotransformation displays each MC included in the application along with its CASRN. The user selects each MC that is treated with phytotransformation and MC-specific values for the plant growth rate G , bioconcentration ration BCR , and fraction of MC mass taken up by the plant that is transformed, f_T . Each of these three inputs is constant over time for each MC. Although not shown in the phytotransformation preliminary input screen of Figure 5, an input table is provided for entering the time-varying fraction of AOI area that is treated with phytotransformation, f_P . This table will be similar to the one described above for soil removal and burning. After entering the time pairs for f_P , the user can view the computed MC removal rate and half life due to phytotransformation for each time point. The UI checks to ensure that none of the f_P inputs for any MC is greater than 1.0 for all time pairs. Additionally, the fraction f_T is not allowed to exceed 1.0.

Figure 5. Preliminary input screen for phytotransformation BMP.

Select	Name	CASRN	Fraction of AOI area that is treated with phytotransformation	Plant production rate (kg dry plant mass/m ² -yr)	Bioconcentration ratio (mg MC in plant/kg plant/mg MC in soil/kg soil) where all mass is dry	Fraction of plant uptake (bioaccumulation) of MC that is transformed	Calculated phytotransformation degradation rate (/yr)	Calculated phytotransformation half-life (yr)	Calculated overall half-life (yr)
<input type="checkbox"/>	lead	7439921							
<input checked="" type="checkbox"/>	rdx	121824	.2	10	10	1	0.036359555605...	19.059638888889	6.557887515937...

Phytoextraction

As for the input screen described above, the input screen for phytoextraction displays each MC included in the application along with its CASRN. The user selects each MC that is treated with phytoextraction and enters the plant production rate and bioconcentration ratio for that MC. An input table of time pairs for plant harvesting fraction f_H is provided for each selected MC, where the user enters the year and the fraction. As explained in Chapter 2, the plant harvesting fraction is actually the fraction of AOI area that is treated with phytoextraction. As a result, the UI checks to ensure that none of the f_H inputs for any MC is greater than 1.0 for all time pairs. Figure 6 shows the preliminary input screen for this BMP. The user can also view the calculated phytoextraction removal rate R_{ns} for each input year.

Figure 6. Preliminary input screens for phytoextraction BMP.

Select	Name	CASRN	Plant Production Rate (kg dry plant mass/m ² -yr)	Bioconcentration ratio	Plant Harvesting Rate	View Calculated Rs and Rns
<input type="checkbox"/>	lead	7439921				
<input checked="" type="checkbox"/>	rdx	121824				

Time (yr)	Plant Harvesting Fraction
0	0.25
100	0.25
<input type="text"/>	<input type="text"/>
*	

Selective MC removal

Again, this input screen displays each MC included in the application along with its CASRN, and the user selects each MC that is selectively removed via removal of mass chunks. For each selected MC, there is a time pair input table for the user to enter the year and the removal rate SR (grams/year) as shown in Figure 7.

Figure 7. Preliminary input screens for selective MC removal BMP.

Note: Removal of duds can be handled within the 'Site Conditions/Operational Inputs' screen by setting percent sympathetic duds to 0 within the 'Munitions usage information' panel.

Select MC to which selective removal applies and provide rates:

Select	Name	CASRN	Removal Rate
<input checked="" type="checkbox"/>	lead	7439921	<input type="text"/>
<input type="checkbox"/>	rdx	121824	<input type="text"/>

Enter/Edit time-varying MC Selective Removal Rates

Selective removal rate for MC: lead (7439921)

Time (yr)	Selective Removal Rate (g/yr)
0	10000
100	10000
*	

AOI export treatment BMP inputs

The input information associated with the AOI export treatment BMPs is presented in this section.

Degradation reactor

Input for the reactor model include the following reactor parameters: length L_r (meters), width W_r (meters), height H_r (meters), porosity ϕ_r , dry bulk density ρ_{br} (kilograms/liter), and fraction of AOI surface water export that is treated, f_t . Three MC-specific inputs are required, which include: reactor sorption distribution coefficient K_{dr} (liters/kilogram) for partitioning of MC between pore water and reactor solid medium; reactor reaction rate λ_r (per day); and sorption distribution coefficient K_{dw} (liters/kilogram) for partitioning of MCs between water and TSS. Figure 8 shows the preliminary input screen. The input for K_{dw} is not needed or used for a vadose zone reactor, but this input field is retained since the same UI and model are used for surface water and vadose zone reactors. The values for the MC sorption partitioning coefficients K_{dr} and K_{dw} can be quite different. Likewise, values of K_{dw} can be different from partitioning coefficients for soil and sediment pore water.

Figure 8. Preliminary input screen for degradation reactor BMP.

Site Characteristics						Soil Properties						Hydrology						Fate/Transport Parameters						Chemical-Specific Properties						Miscellaneous																	
Degradation Reactor for SW												Degradation Reactor for VZ												Degradation Reactor for SW and VZ												Sedimentation Basin for SW											
Reactor length																								<input type="text"/>																							
Reactor width																								<input type="text"/>																							
Reactor height																								<input type="text"/>																							
Reactor porosity																								<input type="text"/>																							
Reactor bulk density																								<input type="text"/>																							
Fraction of AOI SW export that is treated																								<input type="text"/>																							
<table border="1"> <thead> <tr> <th></th> <th>MC Name</th> <th>CASID</th> <th>Reactor Kdr (L/kg)</th> <th>Reactor reaction rate (1/day)</th> <th>TSS-water Kdw</th> </tr> </thead> <tbody> <tr> <td>▶</td> <td>lead</td> <td>7439921</td> <td></td> <td></td> <td></td> </tr> <tr> <td></td> <td>rdx</td> <td>121824</td> <td></td> <td></td> <td></td> </tr> </tbody> </table>																									MC Name	CASID	Reactor Kdr (L/kg)	Reactor reaction rate (1/day)	TSS-water Kdw	▶	lead	7439921					rdx	121824									
	MC Name	CASID	Reactor Kdr (L/kg)	Reactor reaction rate (1/day)	TSS-water Kdw																																										
▶	lead	7439921																																													
	rdx	121824																																													

Sedimentation basin

Input for the sedimentation basin model include the following basin parameters: surface area A_b (square meters), mean depth H_b (meters), TSS settling rate v_s (meters/day), and fraction of AOI surface water export that is treated f_t . The basin volume V_b used in the model is the product $A_b H_b$. One MC-specific input is required, which is the sorption distribution coefficient K_{dw} (liters/kilogram) for partitioning of MCs between water and TSS. Figure 9 shows the preliminary input screen.

Figure 9. Preliminary input screen for sedimentation basin BMP.

Site Characteristics						Soil Properties						Hydrology						Fate/Transport Parameters						Chemical-Specific Properties						Miscellaneous BMP Info																													
Degradation Reactor for SW												Degradation Reactor for VZ												Degradation Reactor for SW and VZ												Sedimentation Basin for SW												Tandem											
Sedimentation basin surface area																								<input type="text"/>																																			
Sedimentation basin mean depth																								<input type="text"/>																																			
Suspended sediment settling rate																								<input type="text"/>																																			
Fraction of AOI SW export that is treated																								<input type="text"/>																																			
<table border="1"> <thead> <tr> <th></th> <th>MC Name</th> <th>CASID</th> <th>TSS-water Kdw</th> </tr> </thead> <tbody> <tr> <td>▶</td> <td>lead</td> <td>7439921</td> <td></td> </tr> <tr> <td></td> <td>rdx</td> <td>121824</td> <td></td> </tr> </tbody> </table>																									MC Name	CASID	TSS-water Kdw	▶	lead	7439921			rdx	121824																									
	MC Name	CASID	TSS-water Kdw																																																								
▶	lead	7439921																																																									
	rdx	121824																																																									

Vadose zone reactor and tandem treatment

The inputs for the vadose reactor are identical to the reactor inputs presented above except for the labeling, i.e., surface water (SW) versus vadose zone (VZ). The inputs for the tandem model are merely a combination of inputs for a reactor and sedimentation basin except that

the input for fraction treated by the reactor is eliminated since it is a redundant input.

Outputs

Source removal

Source removal BMPs affect AOI soil MC mass and concentration and MC mass transported from the AOI; thus, there are no direct outputs associated with source removal BMPs. However, there are the inputs calculated by the UI for input to the soil model that were described previously in this chapter. The effects of source removal BMPs are manifested by changes in AOI soil MC mass and concentration and mass flux exiting the AOI.

AOI export treatment

Unlike the source removal BMPs, each of the AOI export treatment BMPs has viewable output. This output is produced by the three AOI export treatment models (reactor, sedimentation basin, and tandem sedimentation basin, followed by reactor), and it is used to process input via WFFs for any down-gradient receiving water model. Users can view AOI export treatment output by going to the *View Results* tab and selecting *AOI Export treatment BMP Output* under the *Soil Viewer* of TREECS™. Figure 10 shows an example output for tandem treatment. The output includes an echo print of input parameters and tabular daily values for each MC of: entering MC mass flux (fluxin), entering MC total concentration, MC total concentration exiting the sedimentation basin, MC total concentration exiting the tandem system, MC mass flux exiting the tandem system, particulate (part) mass flux delivered to down-gradient (DG) models, dissolved (diss) mass flux delivered to DG models, TSS concentration in the sedimentation basin, and sedimentation basin time step. Output for the reactor and sedimentation basin are similar but involve less information than that produced by the tandem model. Output of all three models includes down-gradient dissolved and particulate fluxes.

Figure 10. Example output for tandem AOI export treatment BMP.

Test case for generic sedimentation basin and reactor in tandem for range BMPs												
Tandem sedimentation basin and reactor inputs												
Sedimentation basin surface area Ab, m^2												
Sedimentation basin mean depth H, m												
TSS settling rate, m/day												
Reactor length Lr, m												
Reactor width Wr, m												
Reactor depth Hr, m												
Reactor porosity												
Reactor bulk density, kg/L												
Fraction treated												
number of MC												
Constituent												
CAS ID												
TSS-water Kd, L/kg												
reactor Kd, L/kg												
reactor reaction rate, 1/day												
Year	Month	Day	Fluxin total, g/day	CTIn mg/L	Cbasin mg/L	CTout mg/L	Fluxout total, g/day	DG part Flux g/day	DG diss Flux g/day	Basin TSS mg/L	Basin dt day	
1950	1	1	0.00	0.0000	0.0000	0.0000	0.00	0.00	0.00	0.00	0.200	
1950	1	2	0.00	0.0000	0.0000	0.0000	0.00	0.00	0.00	0.00	0.200	
1950	1	3	430.00	0.1333	0.0632	0.0048	15.63	1.35	14.28	6689.63	0.200	
1950	1	4	0.00	0.0000	0.0631	0.0000	0.00	0.00	0.00	4486.22	0.200	
1950	1	5	0.00	0.0000	0.0630	0.0000	0.00	0.00	0.00	3008.57	0.200	
1950	1	6	0.00	0.0000	0.0629	0.0000	0.00	0.00	0.00	2017.62	0.200	
1950	1	7	430.00	0.1095	0.0880	0.0106	41.67	2.85	38.82	8307.15	0.200	
1950	1	8	0.00	0.0000	0.0878	0.0000	0.00	0.00	0.00	5570.97	0.200	
1950	1	9	0.00	0.0000	0.0877	0.0000	0.00	0.00	0.00	3756.03	0.200	
1950	1	10	0.00	0.0000	0.0876	0.0000	0.00	0.00	0.00	2505.47	0.200	
1950	1	11	0.00	0.0000	0.0875	0.0000	0.00	0.00	0.00	1686.33	0.200	

4 Summary

This report provides formulations used for the source removal and AOI export treatment BMPs and guidelines for their final implementation within TREECS™. Work was initiated but not completed on the coding to implement these BMPs within TREECS™. Following the initial implementation within TREECS™, some of the formulations were modified, and improvements were made in the plans for interfacing these BMP modules within TREECS™. Thus, this report serves to document the final formulations and provide information for final implementation within TREECS™. This report also documents the BMP module input requirements and output.

References

- Dortch, M. S., B. E. Johnson, Z. Zhang, and J. A. Gerald. 2011. *Methods for Tier 2 Modeling within the Training Range Environmental Evaluation and Characterization System*. ERDC/EL TR-11-2. Vicksburg, MS: U.S. Army Engineer Research and Development Center.
- Dortch, M. S., B. E. Johnson, and J. A. Gerald. 2013. *Modeling Firing Range Best Management Practices with TREECS™*. ERDC/EL TR-13-6. Vicksburg, MS: U.S. Army Engineer Research and Development Center.
- Dortch, M. S. 2014 (in preparation). *Modeling the Fate of Lead from Small Arms Firing Ranges, Fort Jackson, SC*. ERDC/EL CR-14-X. Vicksburg, MS: U.S. Army Engineer Research and Development Center.
- Gent, D. B., J. L. Johnson, D. R. Felt, G. O'Connor, E. Holland, S. May, and S.L. Larson. 2010. *Laboratory Demonstration of Abiotic Technologies for Removal of RDX from a Process Waste Stream*. ERDC TR-10-8. Vicksburg, MS: U.S. Army Engineer Research and Development Center.
- Larson, S. L., P. G. Malone, C. A. Weiss, W. A. Martin, C. Trest, G. Fabian, M. F. Warminsky, D. Mackie, J. J. Tasca, J. Wildey, and J. Wright. 2007. *Amended Ballistic Sand Studies to Provide Low Maintenance Lead Containment at Active Small Arms Firing Range Systems*. ERDC TR-07-14. Vicksburg, MS: U.S. Army Engineer Research and Development Center.
- Larson, S. L., J. L. Davis, W. A. Martin, D. R. Felt, C. C. Nestler, G. Fabian, G. O'Connor, G. Zynda, and B. A. Johnson. 2008. *Grenade Range Management Using Lime for Dual Role of Metals Immobilization and Explosives Transformation*. ERDC TR-08-24. Vicksburg, MS: U.S. Army Engineer Research and Development Center.
- Zheng, C., and P. Wang. 1999. "MT3DMS: a Modular Three-Dimensional Multispecies Transport Model for Simulation of Advection, Dispersion, and Chemical Reactions of Contaminants in Groundwater Systems: Documentation and User's Guide," Contract Report SERDP-99-01. Vicksburg, MS: U.S. Army Engineer Research and Development Center.

REPORT DOCUMENTATION PAGE

Form Approved
OMB No. 0704-0188

Public reporting burden for this collection of information is estimated to average 1 hour per response, including the time for reviewing instructions, searching existing data sources, gathering and maintaining the data needed, and completing and reviewing this collection of information. Send comments regarding this burden estimate or any other aspect of this collection of information, including suggestions for reducing this burden to Department of Defense, Washington Headquarters Services, Directorate for Information Operations and Reports (0704-0188), 1215 Jefferson Davis Highway, Suite 1204, Arlington, VA 22202-4302. Respondents should be aware that notwithstanding any other provision of law, no person shall be subject to any penalty for failing to comply with a collection of information if it does not display a currently valid OMB control number. **PLEASE DO NOT RETURN YOUR FORM TO THE ABOVE ADDRESS.**

1. REPORT DATE (DD-MM-YYYY) July 2015		2. REPORT TYPE Final report		3. DATES COVERED (From - To)	
4. TITLE AND SUBTITLE Modules for Modeling Firing Range Best Management Practices within TREECS™				5a. CONTRACT NUMBER	
				5b. GRANT NUMBER	
				5c. PROGRAM ELEMENT NUMBER	
6. AUTHOR(S) Mark S. Dortch and Jeffrey A. Gerald				5d. PROJECT NUMBER	
				5e. TASK NUMBER	
				5f. WORK UNIT NUMBER	
7. PERFORMING ORGANIZATION NAME(S) AND ADDRESS(ES) U.S. Army Engineer Research and Development Center, Environmental Laboratory, 3909 Halls Ferry Road, Vicksburg, MS 39180-6199				8. PERFORMING ORGANIZATION REPORT NUMBER ERDC/EL TR-15-7	
9. SPONSORING / MONITORING AGENCY NAME(S) AND ADDRESS(ES) U.S. Army Corps of Engineers Washington, DC 20314-1000				10. SPONSOR/MONITOR'S ACRONYM(S)	
				11. SPONSOR/MONITOR'S REPORT NUMBER(S)	
12. DISTRIBUTION / AVAILABILITY STATEMENT Approved for public release; unlimited distribution.					
13. SUPPLEMENTARY NOTES					
14. ABSTRACT The Training Range Environmental Evaluation and Characterization System (TREECS™) was developed for Army firing and training ranges. TREECS contains varying levels of capability to forecast the fate and risk of munitions constituents (MC), such as metals and high explosives (HE), located within firing and training ranges and transported to surface water and groundwater. The overall purpose of TREECS™ is to provide environmental specialists with tools to assess the potential for MC migration into surface water and groundwater systems and to assess military range management strategies to ensure protection of human health and the environment. TREECS™ can be used to assess best management practices (BMPs) for military ranges to avoid, reduce, and remediate MC concentrations in receiving waters. New modules for simulating the effectiveness of BMPs have been developed for future implementation into TREECS™. This report documents the final mathematical formulations, model implementation protocols, and input requirements of these modules.					
15. SUBJECT TERMS BMPs		Modeling fate of munitions constituents (MC)		Training Range Environmental Evaluation and Characterization System (TREECS™)	
16. SECURITY CLASSIFICATION OF:			17. LIMITATION OF ABSTRACT	18. NUMBER OF PAGES 44	19a. NAME OF RESPONSIBLE PERSON
a. REPORT UNCLASSIFIED	b. ABSTRACT UNCLASSIFIED	c. THIS PAGE UNCLASSIFIED			19b. TELEPHONE NUMBER (include area code)